

GEMINI EXPRESS MULTIPLEXER

User's Guide



TABLE OF CONTENTS

SAFETY	3
Federal Communications Commission (FCC) Statement	3
Classification of LED Transmitter Device	4
INTRODUCTION	5
UNPACKING	6
ACTIVE PAIR SETUP	7
DESCRIPTION	8
CONFIGURATION	9
MODE DESCRIPTION	10
COLLAPSED RINGS	11
CONNECTIONS	12
INSTALLATION	16
Host side multiplexer installation	16
Device side multiplexer installation.	17
PROBLEM SOLVING	19
The MULTIPLEXER 's front panel power LED is off!	19
The MULTIPLEXER's RX LED is off or flashing!	19
The MULTIPLEXER 's TX LED is off!	19
A device is down or unstable!	19
Devices interfere with each other!	20
Devices cannot operate in Express mode!	20
Flashing Express LEDs!	20
Express LEDs on without data activity!	20
SPECIFICATIONS	21
WARRANTY STATEMENT	23
RETURN MERCHANDISE PROCEDURE	23

SAFETY

Note: READ THIS FIRST

1. Do not look into any fiber optic connection or fiber optic cable.
2. Do not connect GEMINI EXPRESS MULTIPLEXER to any type of public network.
3. Do not connect any outdoor cabling to the GEMINI EXPRESS MULTIPLEXER without proper lightning protection.
4. Do not use unauthorized power supplies or cables.
5. Do not connect to non-5250 protocol devices.
6. Do not disassemble or modify the power supply and its cables.
7. Disconnect all cables prior to configuration.
8. Devices attached to the UTP network must comply with the voltage and current limits for Class 2 Power-Limited Signal Circuits as defined by article 725 of the National Electrical Code and Section 16 of the Canadian Electrical Code.
9. For your safety, receptacles must be properly wired and grounded.
10. Never attempt to service equipment connected to the data cable network or the grounded receptacle during an electrical storm. Exposure to lethal voltages may occur when lightning is present.

The following FCC statement applies to the N Lynx GEMINI EXPRESS MULTIPLEXER.

Federal Communications Commission (FCC) Statement

Note: This equipment has been tested and found to comply with the limits for a Class A digital device, pursuant to Part 15 of the FCC Rules. These limits are designed to provide reasonable protection against harmful interference when the equipment is operated in a commercial environment. This equipment generates, uses, and can radiate radio frequency energy and, if not installed and used in accordance with the instruction manual, may cause harmful interference to radio communications. Operation of this equipment in a residential area is likely to cause harmful interference, in which the user will be required to correct the interference at his own expense. Unauthorized changes or modifications could void the user's authority to operate the equipment.

This device complies with Part 15 of the FCC Rules. Operation is subject to the following two conditions: (1) this device may not cause harmful interference, and (2) this device must accept any interference received, including interference that may cause undesired operation.

Classification of LED Transmitter Device Important:

The optical transmitter contains an LED system and is classified “CLASS 1 LED PRODUCT” per EN60825-1 (+A11), Safety of Laser Products. Contact NLynx Technologies for repair if your GEMINI EXPRESS MULTIPLEXER ever requires maintenance.

INTRODUCTION

This user's manual presents the GEMINI EXPRESS MULTIPLEXER for use with the IBM 5250 protocol. The 5250 family of products consists of the IBM's System 34, 36, 38, and the AS/400 along with many supporting devices manufactured by IBM and other companies. The GEMINI EXPRESS MULTIPLEXER works with all supporting devices that are designed within the 5250 specifications.

GEMINI EXPRESS MULTIPLEXER

Decision Data's MULTIPLEXER Gemini Eight-Port *Express* Fiber Optic Multiplexer offers the unique ability to allow multiple AS/400 controller polling groups to be transmitted over a single fiber optic pair. This feature allows all new AS/400e controllers to provide their maximum throughput potential, in either 1Mbps *Optimized* or 2Mbps *Express* mode, by transparently multiplexing the "split-polling" feature without requiring performance robbing PTF's. All new IBM controllers support the "split-polling" feature as a means of achieving higher throughput rates, even when connected to standard legacy devices. The Gemini Express Multiplexer allows the "split-polling" feature to remain "enabled" with performance of up to 4 times greater than standard legacy 1Mbps 5250 protocol. The Gemini Express Multiplexer has 8 Shielded RJ45 port connections as well as a DB25 "direct-connection" eliminating the need for the twinax "brick" and associated twinaxial cabling. Link connectivity is via ST fiber optic multi-mode connection with ability to operate in both point-to-point and multi-point "ring" topologies, reducing hardware requirements by up to 50%. Other features include Advanced Noise Filtering, LED Port Diagnostics, Configurable UTP Pin Assignments, and a Field Replaceable wide-ranging Power Supply.

UNPACKING

Remove the packing material and check for the items below:



GEMINI EXPRESS MULTIPLEXER

A (100-240 VAC) input external power supply is attached on the rear panel.

USER'S MANUAL

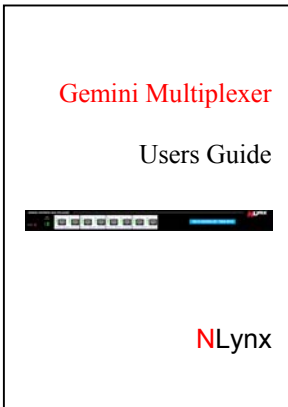

AC POWER CORD



(North American units only)

Visually inspect all items for damage. If any component is damaged, contact N Lynx Technologies for a replacement.

DO NOT APPLY POWER TO ANY DAMAGED COMPONENT!

ACTIVE PAIR SETUP

All GEMINI EXPRESS MULTIPLEXERS can be factory configured per customer request. The factory default setting is Pins 4 & 5. Different configurations will be indicated on the label on the bottom of the unit.

IDENTIFICATION LABEL

The active pair may be re-configured by performing the following procedure:

- Disconnect all power to the unit.
- Remove the two top cover screws located on the rear panel.
- Gently slide the top cover back one inch.
- Hold the top cover and tilt it up.

Reconfigure the jumpers located behind the RJ45 connectors as required. Settings for polarity and active pair assignment are shown below:

ACTIVE PAIR JUMPER SETTINGS

It should be noted that connections to the DB25 and the RJ45s are mutually exclusive. If any of the three pairs of the RJ45 are selected, the DB25 is disconnected. If the DB25 is selected, the RJ45s are disconnected. All jumper settings must be identical. To reinstall the top cover, tilt the top cover down, and slide the top cover forward until it mates completely with the bottom cover. Install the 2 top cover screws.

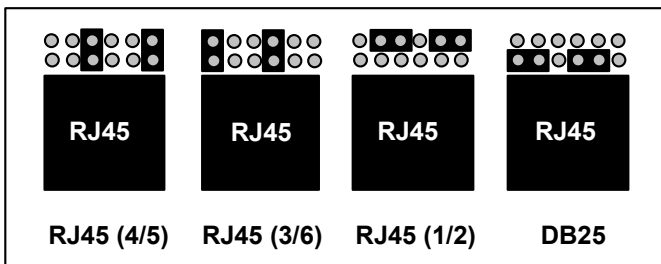

DESCRIPTION

The GEMINI EXPRESS MULTIPLEXER's indicators and connections are described below.

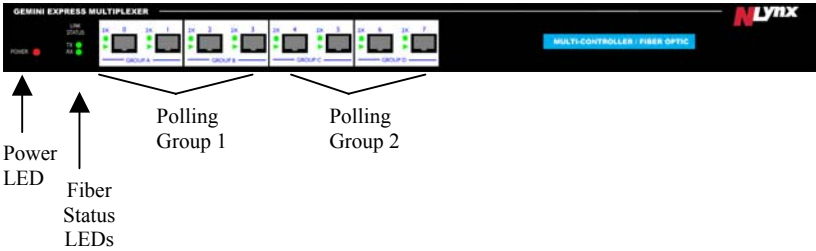

Power LED Amber LED activates when the GEMINI EXPRESS MULTIPLEXER is powered up.

TX Activity LED Green LED activates when a signal is transmitted to the fiber optic aggregate link.

RX Activity LED Green LED activates when a signal is received from the fiber optic aggregate link and the MULTIPLEXER synchronizes to it.

Polling Group Status LEDs The upper green LEDs are express mode indicators. These LEDs activate when an express signal is detected and remain on until a 1MBPS signal is detected or a system reset occurs. The lower green LEDs are data activity indicators. These LEDs activate when a signal is present.

Polling Group Connectors There are two polling groups. Each polling group has been divided into two port groups. Polling group #1 consists of ports 0 - 3 (port groups A & B) and Polling group #2 consists of ports 4 - 7 (port groups C & D). **Ports within a polling group must be connected to ports from a common controller.**

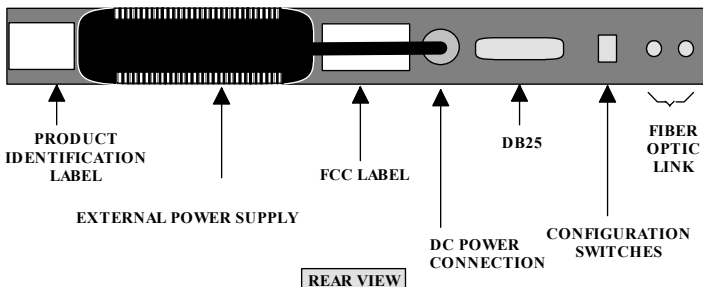

CONFIGURATION

The configuration switch settings are shown below.

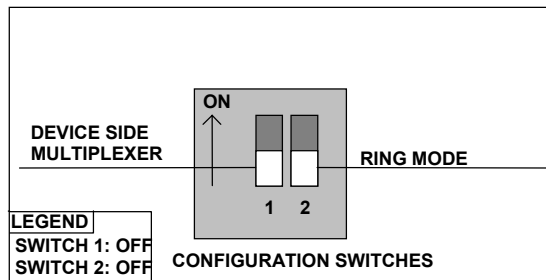
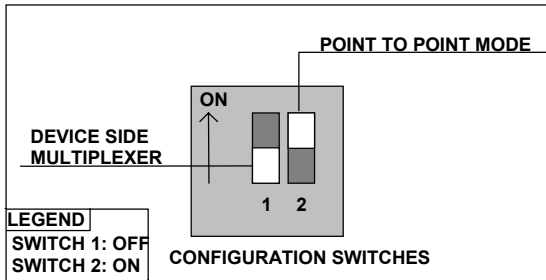
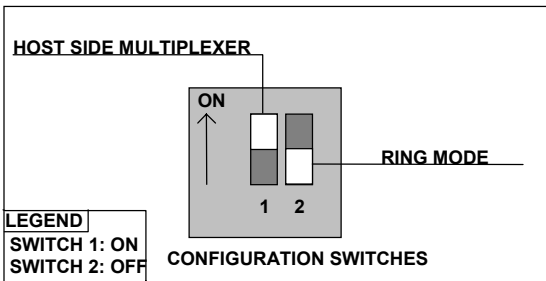
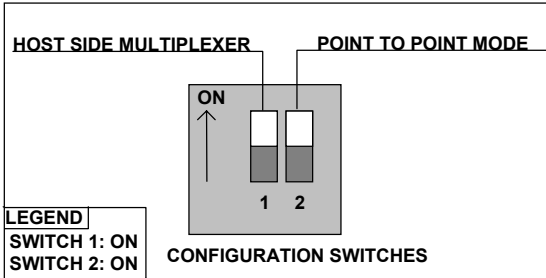

MODE DESCRIPTION

A “POINT TO POINT” link is comprised of two Multiplexer s connected by a single backbone. A diagram of a “POINT TO POINT” link is provided below.

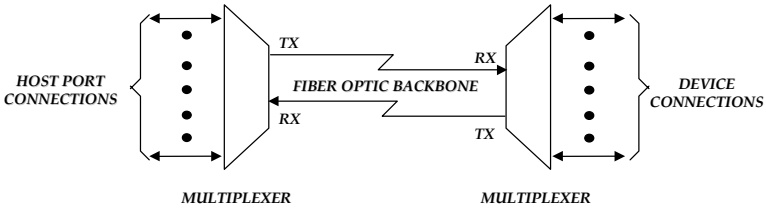

Multiple Multiplexers which are connected in series with fiber optic transmit to fiber optic receive constitute a “RING” topology. A diagram of a “RING” application is provided below.

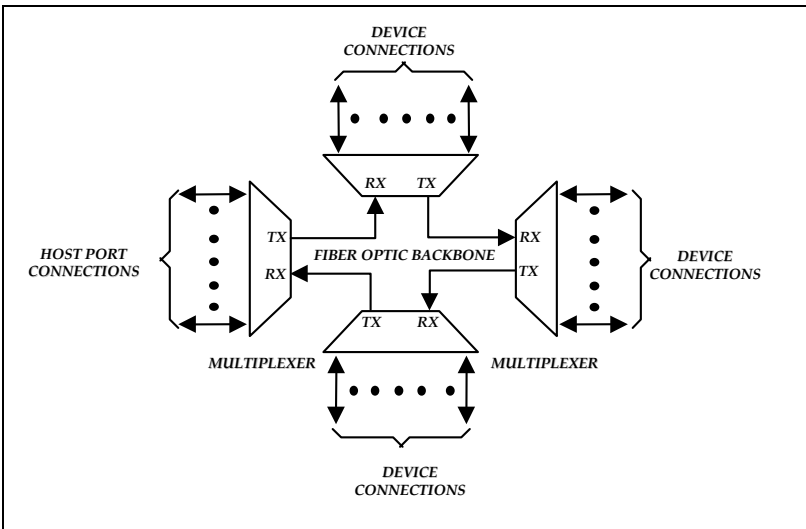

COLLAPSED RINGS

The Ring mode is seldom implemented as depicted in the previous section. Typically, fiber optic cables star out from a central location. Therefore, a ring is created by interconnecting the fiber optic star segments at the central location. This technique is known as a collapsed ring.

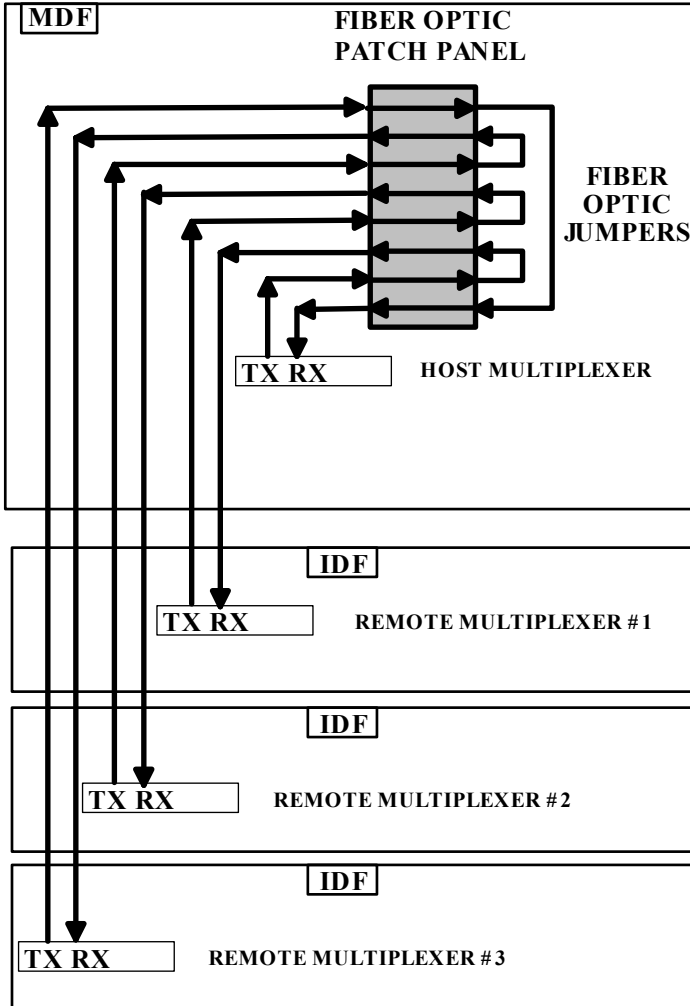

COLLAPSED RING

CONNECTIONS

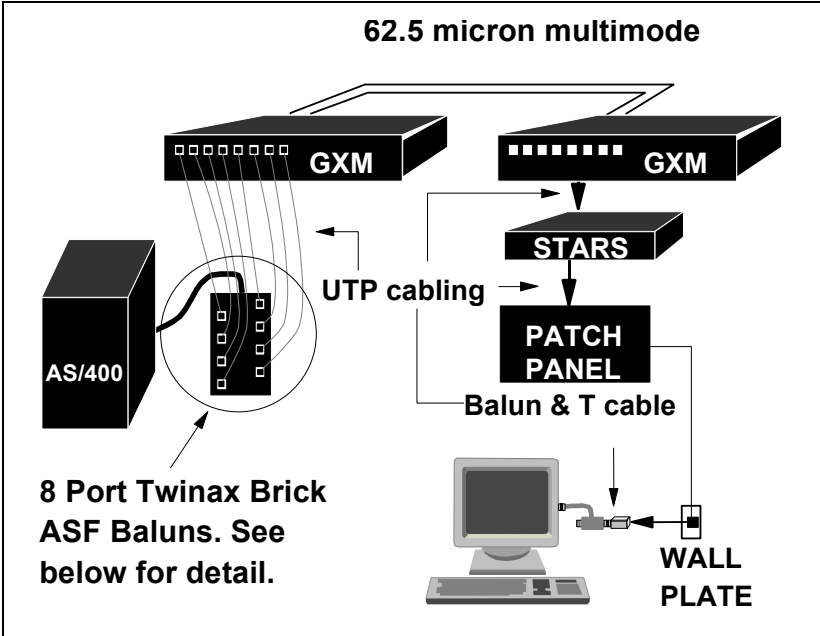

Typical AS/400 Installation

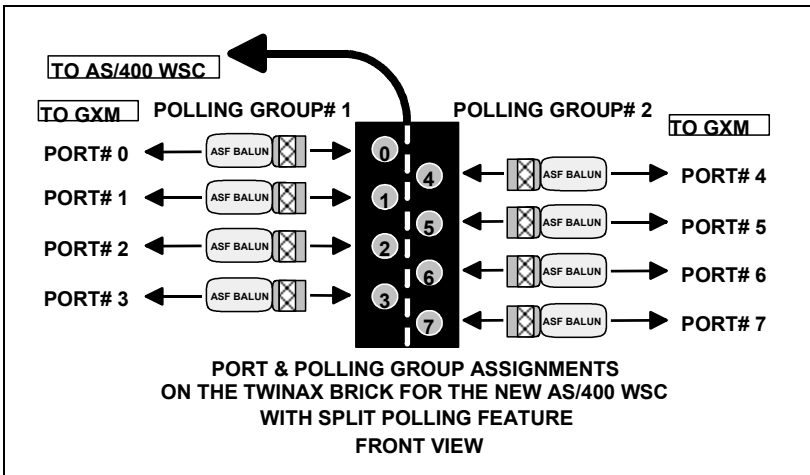

AS/400 Twinax Brick Details

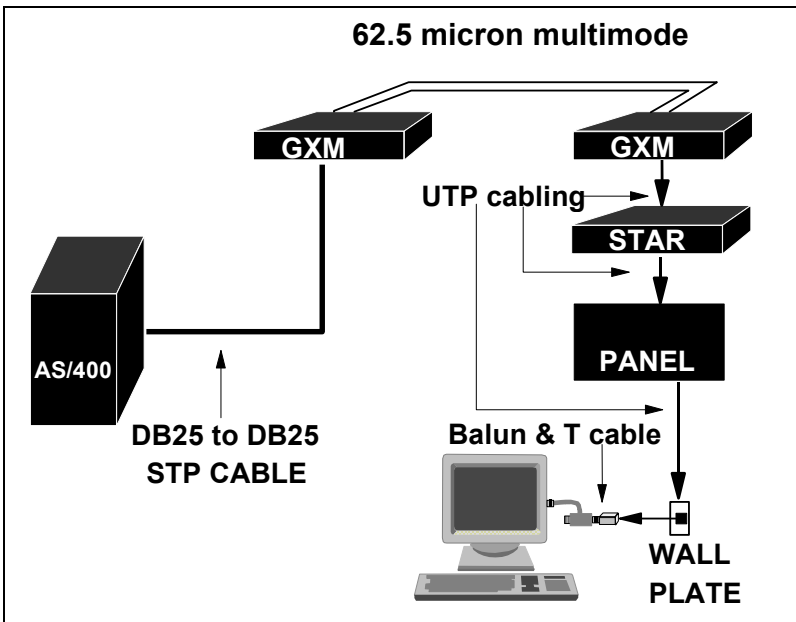

Typical AS/400 Direct Connect Installation

A major difference between the newer AS/400 work station controllers (WSC) and the older WSCs is the number of polling groups. The older WSCs had one polling group for all eight ports. The newer WSCs have two polling groups. Divide the TWINAX brick in two. Ports 0-3 comprise one polling group and ports 4-7 make up the other polling group. The TWINAX Brick Detail illustrates a proper connection.

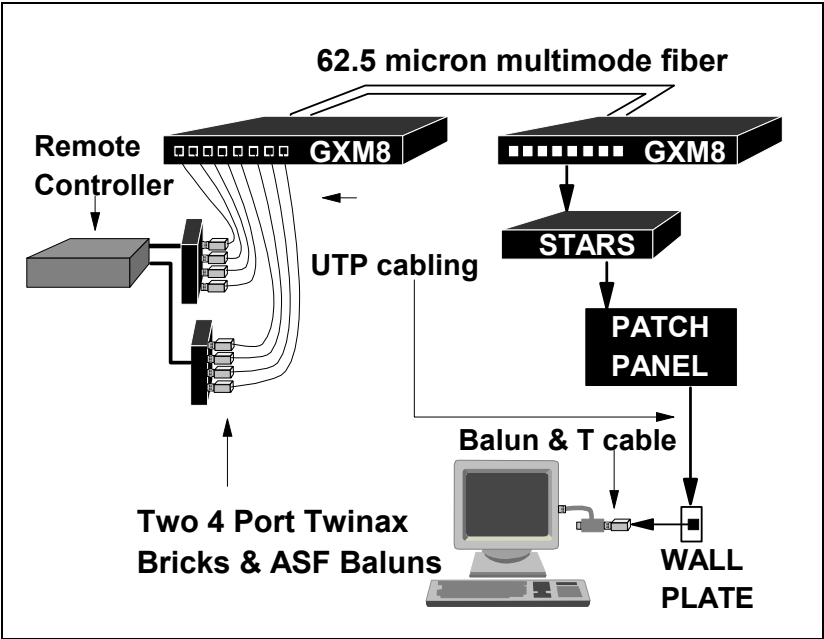

Typical Remote Controller Installation

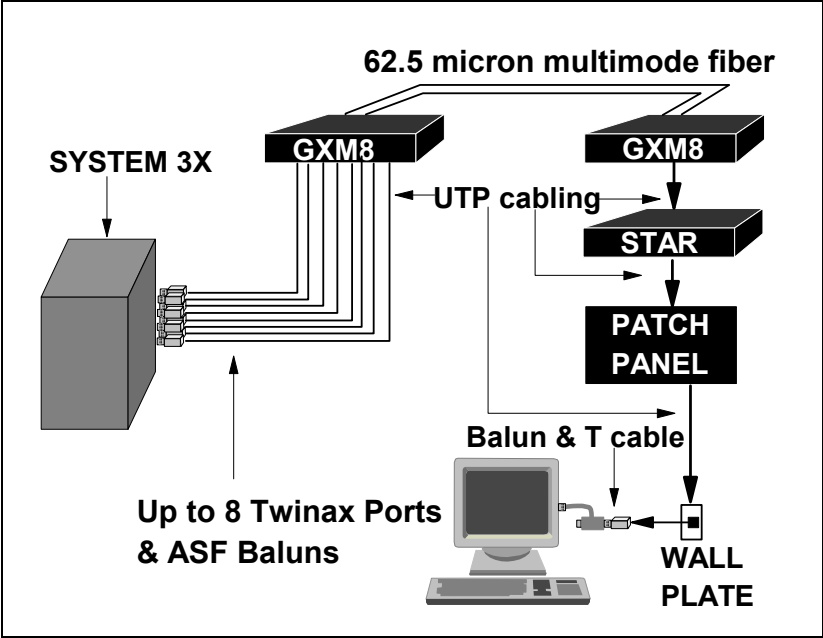

Typical System 3X Installation

INSTALLATION

Host side Multiplexer installation.

1. Set the configuration switches on the rear panel of the host side GEMINI EXPRESS MULTIPLEXER as follows:

SWITCH 1 ON SWITCH 2 ON for a point to point application

or

SWITCH 1 ON SWITCH 2 OFF for a ring application.

2. The GEMINI EXPRESS MULTIPLEXER is designed for a 19" rack. The unit should be properly installed using all four mounting holes. Rack hardware is not provided. It is recommended that plastic or nylon washers be used under mounting screws to protect the chassis's finish.
3. A polling group is a group of ports which have one port active at a time. The new AS/400 work station controllers (WSC) have two polling groups. Ports 0-3 and ports 4-7 constitute the two groups. The GEMINI EXPRESS MULTIPLEXER can accommodate two polling in the same fashion. The GEMINI EXPRESS MULTIPLEXER polling group #1 consists of ports 0-3 and GEMINI EXPRESS MULTIPLEXER polling group #2 consists of ports 4-7. ***Do not connect more than one host polling group to a GEMINI EXPRESS MULTIPLEXER polling group.*** Connect the host ports to the GEMINI EXPRESS MULTIPLEXER ports.

WARNING DO NOT LOOK INTO ANY FIBER OPTIC CONNECTOR OR FIBER OPTIC CABLE!

4. The GEMINI EXPRESS MULTIPLEXER has ST style fiber optic connectors. Connect the multimode fiber optic cables to the optical link connectors located on the rear panel of the MULTIPLEXER. Note the fiber color or number on the "TX" & "RX" to ensure proper connection at the remote multiplexer location. Strain relieve and label all cables.
5. The external power supply is mounted on the rear panel of the GEMINI EXPRESS MULTIPLEXER. The AC power cord must be firmly inserted into the external power supply and strained relieved.

6. Insert the male end of the AC power cord into a properly wired receptacle. All data & mode LED's on the GEMINI EXPRESS MULTIPLEXER will activate for two seconds and fade off. The amber power LED on the front panel, the green power led on the top of the external power supply, and the TX LED will activate and remain on. At this time the data activity LEDs will flash at the host's polling rate. The RX LED will be off until the remote Multiplexer is installed.

Device side Multiplexer installation.

1. Set the configuration switches on the rear panel of the device side GEMINI EXPRESS MULTIPLEXER as follows:

SWITCH 1 OFF SWITCH 2 ON for a point to point application

or

SWITCH 1 OFF SWITCH 2 OFF for a ring application.

2. The MULTIPLEXER is designed for a 19" rack. The unit should be properly installed using all four mounting holes. Rack hardware is not provided. It is recommended that plastic or nylon washers be used under mounting screws to protect the star's finish.

WARNING DO NOT LOOK INTO ANY FIBER OPTIC CONNECTOR OR FIBER OPTIC CABLE!

3. The GEMINI EXPRESS MULTIPLEXER has ST style fiber optic connectors. For point to point applications, connect the multimode fiber optic cable attached to the host side Multiplexer 's "TX" to the device side multiplexer 's "RX" optical link connector located on the rear panel of the GEMINI EXPRESS MULTIPLEXER , and connect the multimode fiber optic cable attached to the host side Multiplexer 's "RX" to the device side Multiplexer 's "TX" optical link connector located on the rear panel of the GEMINI EXPRESS MULTIPLEXER. For ring applications, connect the fiber optic TX of a Multiplexer to the fiber optic RX of the next multiplexer down stream in the ring until the ring is complete. Ensure that the cables are properly strained relieved and labeled.
4. Connect the GEMINI EXPRESS MULTIPLEXER ports to the host ports of the GEMINI active or passive star and follow the installation procedure for the star.

5. The external power supply is mounted on the rear panel of the GEMINI EXPRESS MULTIPLEXER. The AC power cord must be firmly inserted into the external power supply and strained relieved.

6. Insert the male end of the AC power cord into a properly wired receptacle. All data & mode LED's on the GEMINI EXPRESS MULTIPLEXER will activate for two seconds and fade off. The amber power LED on the front panel, the green power LED on the top of the external power supply, and the "TX & RX" LEDs will activate and remain on. If any terminals are on, the data activity LEDs will activate. If express devices and an express host, are attached, the port status LEDs (upper green LEDs) will activate. Devices in a ring application will not show a sign on screen until the ring is complete.

PROBLEM SOLVING

If problems are encountered with the GEMINI EXPRESS MULTIPLEXER, the following guideline is intended to provide a quick resolution.

1. Collect all information relevant to this application.
 - GEMINI EXPRESS MULTIPLEXER serial numbers
 - Host type and operating system software level.
 - Quantity, and type of peripheral devices.
 - Interconnecting cable types and distances.
 - Equipment environment.
 - Interconnection diagrams.
2. Setup the application with all Multiplexers in one room interconnected with fiber optic jumpers. Verify the application with a host port and a terminal.
3. Search through the common problems and possible causes provided below.

The GEMINI EXPRESS MULTIPLEXER front panel power LED is off!

- Verify that the AC & DC connections are proper.
- Verify that the AC outlet is functioning correctly.

If the problem persists, observe the status of the external power supply's LED and contact Decision Data's technical support.

The GEMINI EXPRESS MULTIPLEXER RX LED is off or flashing!

- Verify that the fiber optic connectors are properly connected.
- Verify that the fiber optic budget and distance has not been exceeded.

The GEMINI EXPRESS MULTIPLEXER TX LED is off!

- Contact DECISION DATA technical support.

If problems persists, Contact DECISION DATA technical support.

A device is down or unstable!

- Verify that there is one host polling group per GEMINI EXPRESS MULTIPLEXER polling group.
- Verify that the host's device type matches the device.
- Verify that the host work station controller's (WSC) capacity has not been exceeded.
- Verify that the device is properly terminated. A peripheral is terminated when its twiaxial port has two 54.9 ohm resistors located

between the “A” phase pin & earth ground and the “B” phase pin & earth ground. Termination is provided by a “Y” or “T” cable assembly or by a terminating balun (i.e. ASFT series).

- Verify that there are no polarity reversals in the cable.
- Verify that the cable distance does not exceed the GEMINI EXPRESS MULTIPLEXER specification.
- Verify that the cable is data grade.
- Verify that the wiring uses natural pairs.
- Verify that the wiring avoids sources of environmental noise.
- Verify that the balun’s pinout matches the GEMINI EXPRESS MULTIPLEXER’s pinout.
- Verify that the host side balun’s pinout/polarity match the device side balun’s pinout/polarity.

Devices interfere with each other!

- Verify that there is one host-polling group per GEMINI EXPRESS MULTIPLEXER polling group.
- Verify that devices on star segments have unique addresses.
- Verify that all devices are properly terminated.

Devices cannot operate in Express mode!

- Verify that the host and the device are capable of Express mode.
- Verify that all interconnecting components support the Express mode.
- Verify that all devices on the port are Express ready.
- Verify that all cable distances are within the Express specification.
- The controller may have down shifted to 1MBPS due to errors during installation. The controller will retry the Express mode in approximately one hour.

Flashing Express LEDs!

- Determine the number of Express devices on the port. If there are less than seven devices, the flashing Express LED is normal.

Express LED on without data activity!

- If the host is disconnected during an express connection, the express LED remains on.

SPECIFICATIONS

Protocol	5250
Data rate	1 & 2Mbps (transparent)
Number of ports	8
Port connector types	Shielded RJ45 or DB25

Cable Distances

<u>Cable Type</u>	<u>Data Rate</u>	<u>Location</u>	<u>Distance</u>
Category 3	1X	Host to GXM	up to 2000 ft
Category 3	1X	GXM to Device	up to 1800 ft
Category 3	1X	GXM to GEMINI HUB	up to 1000 ft
Category 3	2X	Host to GXM	up to 1000 ft
Category 3	2X	GXM to Device	up to 900 ft
Category 3	2X	GXM to GEMINI HUB	up to 500 ft
Category 5	1X	Host to GXM	up to 2000 ft
Category 5	1X	GXM to Device	up to 2200 ft
Category 5	1X	GXM to GEMINI HUB	up to 1200 ft
Category 5	2X	Host to GXM	up to 1500 ft
Category 5	2X	GXM to Device	up to 1650 ft
Category 5	2X	GXM to GEMINI HUB	up to 900 ft □

• Note: Distances must be derated as follows:

- 62 ft per category 3 interconnect for 1X.
- 38 ft per category 3 interconnect for 2X.
- 16 ft per category 5 interconnect for 1X.
- 11 ft per category 5 interconnect for 2X.
- Cable distances over 1000' must be derated by 25% for ring applications. □

Distance (fiber optic backbone)
62.5 micron multimode fiber

Point to Point up to 2 Kilometers
Ring (3 Units) up to 1.5 Kilometers between units and up to 4.5 Kilometers overall.

Ring (4 Units) □ up to 1 Kilometers between units and up to 4 Kilometers overall. □

Active data pins	Configurable per customer requirement
Optical Specifications	
Fiber optic budget (point to point)	12 dB (typical)
Fiber optic budget (ring)	
3 unit ring	10 dB (typical)
4 unit ring	8 dB (typical)
Peak power wavelength	820 nanometers
Fiber optic connectors	two ST style
Power requirements	90 to 250 VAC at 50 to 60 Hz
Power supply type	External
Dimensions	1.75" x 19" (1U)
Warranty	Three years

WARRANTY STATEMENT

This NLYnx product is warranted to be free from defects in material and workmanship for a period of three years from the date of purchase. NLYnx's liability under this warranty is limited to cure, repair, or replacement of the product. NLYnx shall not be liable for injury, property damage or other direct, or indirect consequential damage, including but not limited to loss of profits or other damage or expenses arising directly or indirectly from the installation, removal, maintenance, use or non-use of the product used separately or in combination with other equipment.

These warranties shall become void where it is determined, at the sole discretion of NLYnx, that the product has been exposed to excessive physical or operational abuse, acts of God, or theft. Repairs performed by someone other than by NLYnx will void this warranty. This warranty is in lieu of any and all other warranties, expressed or implied, by NLYnx representatives or distribution, including fitness for particular purpose and merchantability.

The customer may, at their option, purchase an Assist Service Agreement that would provide same day overnight shipping response for field replacement of faulty equipment to maintain your data communication system while equipment repairs are completed. Contact our Sales department for further details.

RETURN MERCHANDISE PROCEDURE

In the event that the product is not as warranted, the customer must contact NLYnx for a return merchandise authorization number (RMA#) before returning the product to NLYnx. Out of warranty repairs are available on a time and materials basis. The customer must contact NLYnx for a return merchant number (RMA#) prior to shipping the malfunctioning unit to NLYnx. The customer is responsible for all shipping and insurance charges to and from NLYnx.

NLYnx Limited
4th Floor, The Graftons
Stamford New Road, Altrincham
Cheshire, WA14 1DQ, U.K.
Tel.: +44 (0) 161 928 7014
Fax: +44 (0) 161 928 7015
www.nlynx.co.uk